

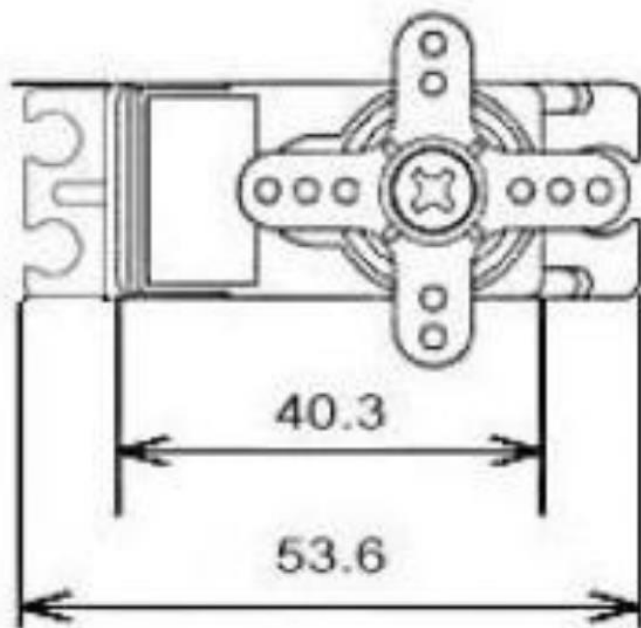

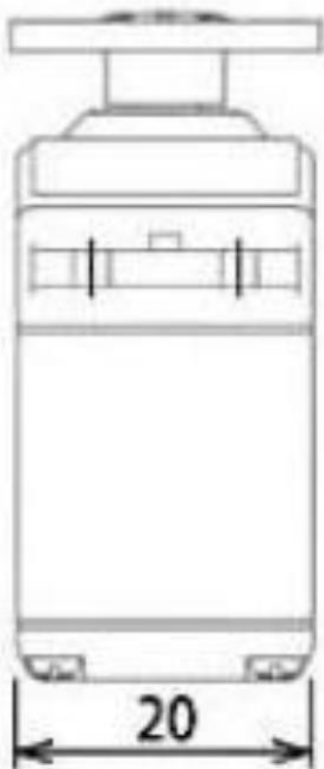

**Detail Specification:**

**Unit: mm**

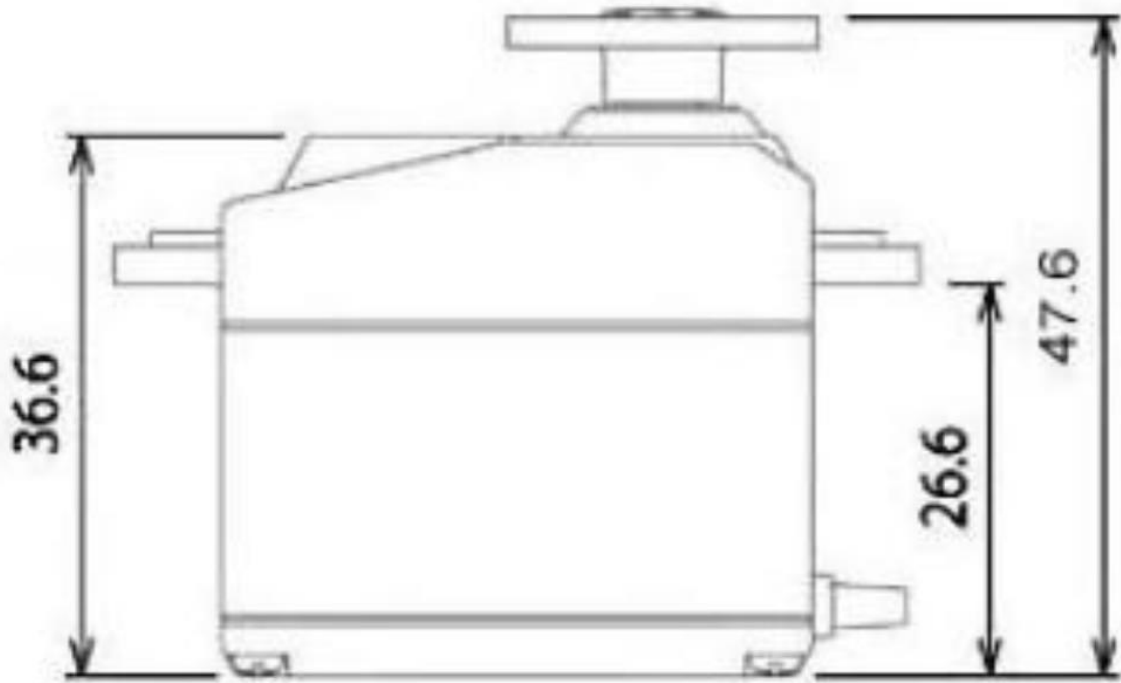

**Electrical Control Signal:**

PWM = Orange (  )  
 Vcc = Red ( + )  
 Ground = Brown ( - )

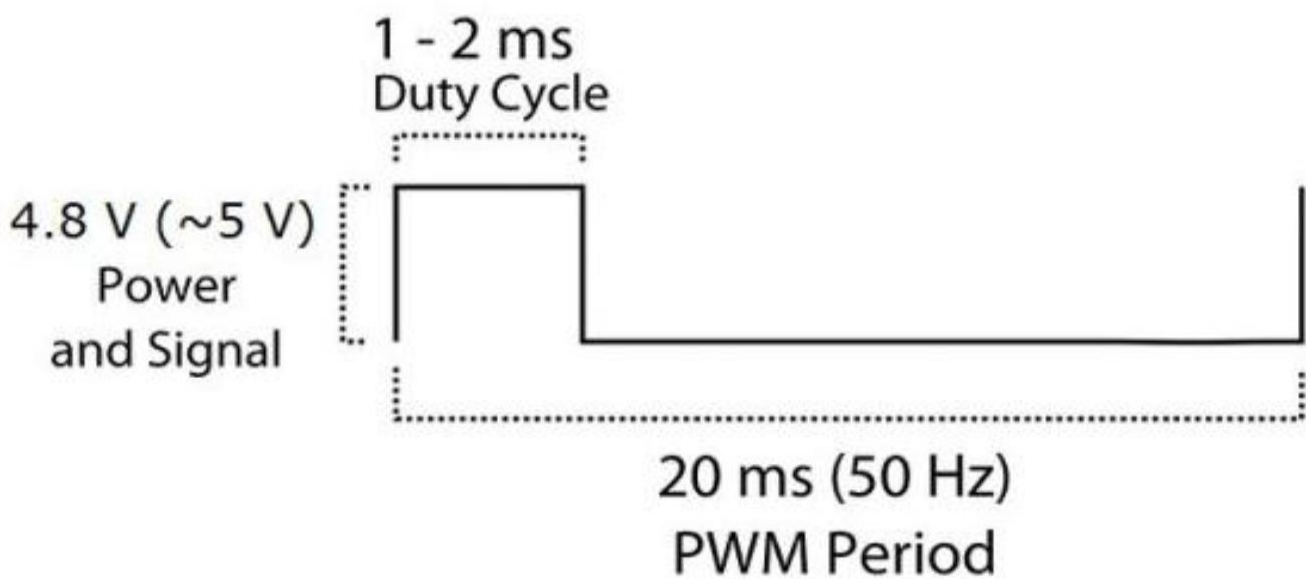
Position "0" (1.5ms pulse) is middle, "90" (~2ms pulse) is middle, is all the way to the right, "-90" (~1ms pulse) is all the way to the left.

**CONNECTOR PINOUT:**

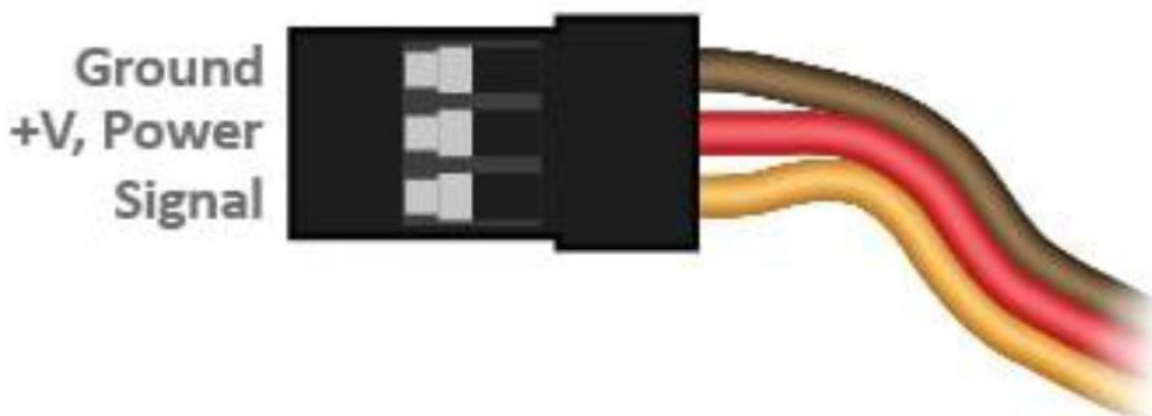

**Application With Arduino:**

**Circuit:**

Servo motors have three wires: power, ground, and signal. The power wire is typically red, and should be connected to the 5V pin on the Arduino board. The ground wire is typically black or brown and should be connected to a ground pin on the board. The signal pin is typically yellow, orange or white and should be connected to pin 9 on the board.

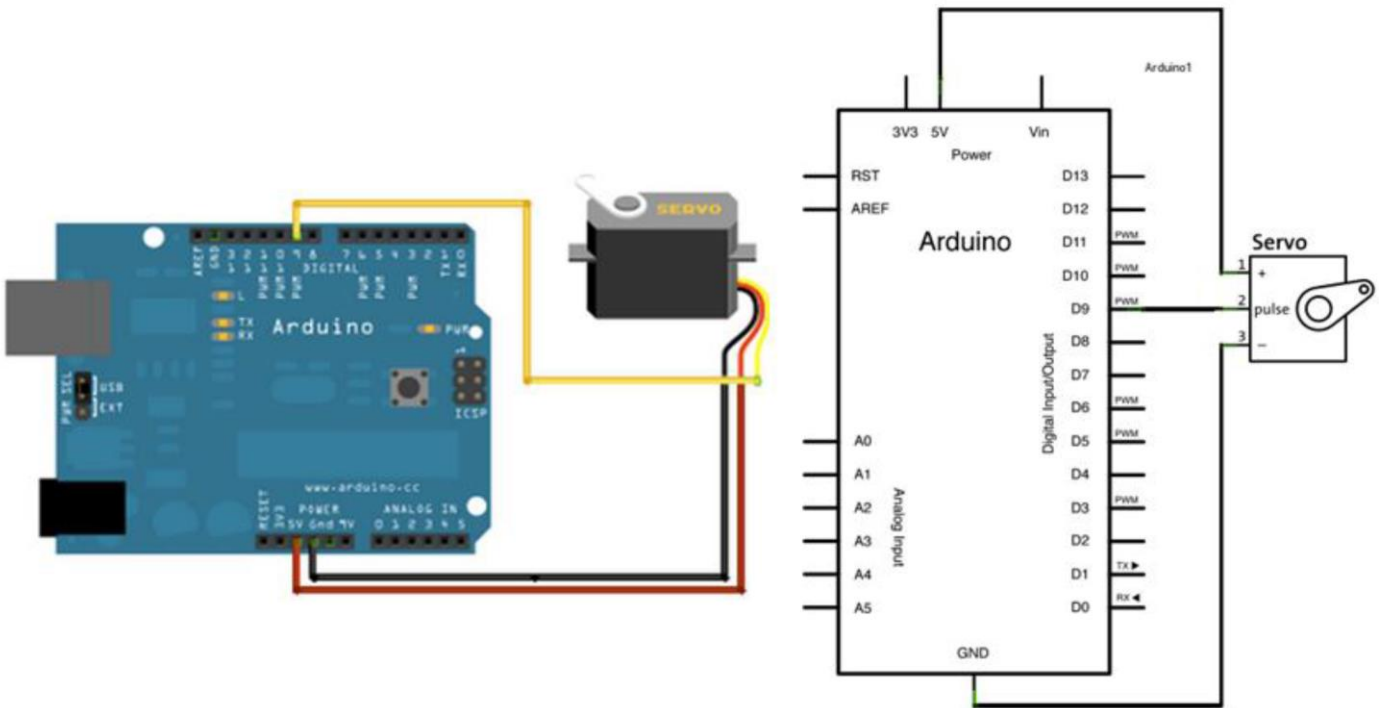

Open Arduino IDE, go to “File” > “Examples” > “Servo” > “Sweep”. Open the “Sweep” sketch and upload to your Arduino board. Attach an arm to the servo motor, you should see the arm sweeping at 180° to and fro.



